

Châssis isolé en neuf ou rénovation
Energie intrinsèque
Ouverture seule

Coupe verticale AA

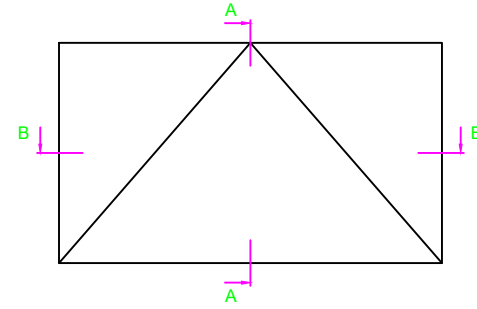

Coupe horizontale BB

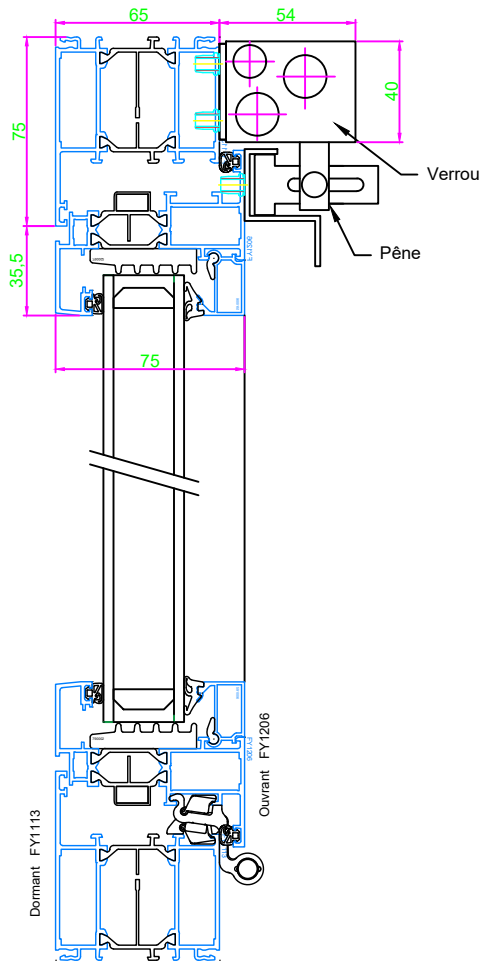